



KB 250-3000 Video, SA, FA
Hardness Testing from 0,2 kgf - 3000 kgf



KB 750 FA



KB 3000 Video

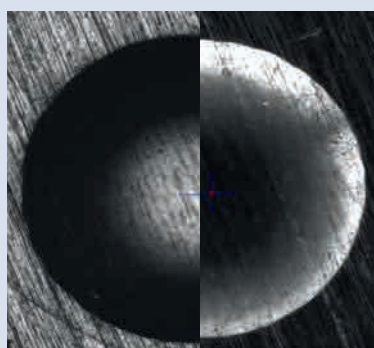

KB 250-3000

VIDEO, SA, FA

**Universal Hardness Testing
Machines**

KB 250

KB 750

KB 1000

KB 3000

Vickers

Knoop

Brinell

Rockwell

Super Rockwell





CONTROL Y MEDICIÓN
LABORATORIO DE CALIBRACIÓN
COMERCIALIZADORA

info@controlymedicion.com
Teléfonos: (044) 340-02-50, 340-02-51

Fax: 442-193-5678

info@controlymedicion.com
www.controlymedicion.com.mx

Universal Hardness Testing Machine KB 250-3000 Video, SA, FA

VIDEO	SA (Semi Automatic)	FA (Fully Automatic)
		
Control via PC	Control via PC Motorized X/Y-table	Control via PC Motorized X/Y-table
Software KB Hardwin XL Video	Software KB Hardwin XL SA semi automat	Software KB Hardwin XL FA fully automat
5 MPs USB camera	5 MPs USB camera	5 MPs USB camera
7x optical zoom optional	7x optical zoom optional	7x optical zoom optional



The new generation of hardness testing machines from KB Prüftechnik GmbH convince by **extraordinary precision and reproducibility**. The user enters a whole new world of hardness testing by the use of the new hardness testing software KB Hardwin XL. The KB hardness testing machines can superiorly test **Brinell, Vickers, Rockwell and Knoop**.

New innovative developments allow new possibilities of automation which combines the function of a fully automatic machine and a universal hardness tester in one machine. The configuration levels combined with numerous additional options suit the KB hardness

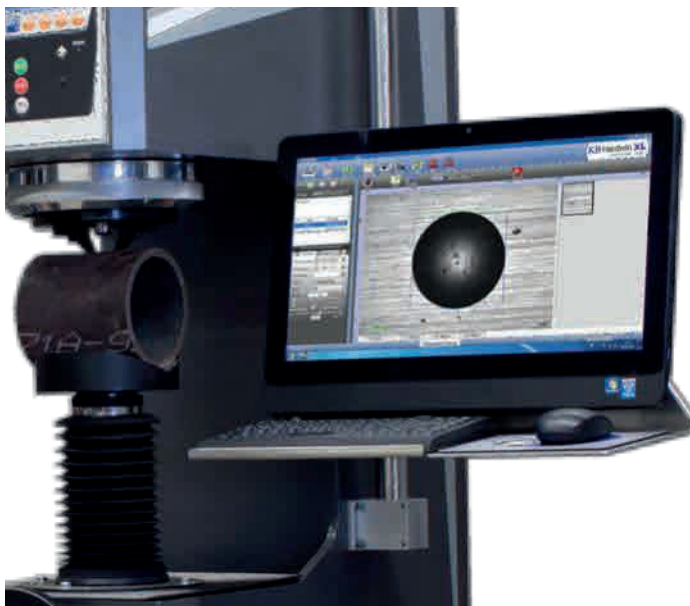

- High precision $1/2,5''$ 5 Megapixels camera 2500 x 2000
- Standard 4x digital zoom with 3 steps
- Clamping cap with flexible holding-down devices
- Automatic change of objective and indenter
- Magnetic indenter holder for the easy change of test tools
- Hardness testing software KB Hardwin XL
- Flexible configuration from single tests to fully automatic test procedures
- Data export to txt, Word, Excel, PDF
- Hierarchically structured user management
- Individually designable test reports
- Network capable
- Automatic load change

Options:

- Huge automatic X/Y-stage travel distance 300x200 mm for KB 250-1000 Semi and Fully
- Optional 7x optical zoom with 10 steps
- Optional auto turret with 6 positions for 2 objectives and 4 indenters
- Huge variety of indenters, test tables and sample supports (example see picture)

Planning and operation

Menu navigation

Perfect test process by a clearly arranged and user-oriented menu navigation

Assistant for easy operation: Solve standard tasks quickly on your own

Apply different magnifications and load steps in



Load step change during one test procedure

Different load steps and magnifications can be applied during one test procedure without breaking into the

	Nr.	Härte	Methode	Umgewertet
Messwerte	1	450	HV 5	---
	2	450	HV 5	---
	3	457	HV 5	---
en	4	842	HV 1	---
	5	717	HV 1	---

USB camera 5 Megapixels

The 5 Megapixels USB camera achieves high quality pictures which are needed for the auto measurement. The 5 Megapixels camera enlarges the optical measur-



Operating system

KB Hardwin XL supports Windows XP, Vista (32 bit), 7 (32 bit/ 64 bit) and 8. The use of a personal computer makes KB Hardwin XL network compatible.



Ring Light

Unique display of the Brinell and Vickers indentations in the darkfield illumination.

Der Eindruck wird hell und die Oberfläche dunkel dargestellt, die Randkante ist klar erkennbar

Schnelle Überprüfung der Eindringkörperqualität für Vickers und Rockwell

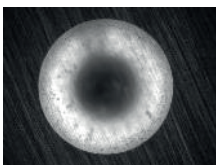

Conversion tables

Conversion tables according to DIN 50150, DIN EN ISO 18265 (without copper conversion) and ASTM-140-T1-9

HB	Nmm ²
HRC	Nmm ²
HV	Nmm ²

Post-editing and archive

Measuring a substitution

There are three possibilities to re-measure an already existing indentation. Primarily, the image will be re-opened and then can be measured. The second possibility is to do a new picture of the old indentation on the live camera. Also a new indentation can be set on



Fast access on filed test orders

Pictures which belong to a previous test order can be re-addressed by one click.

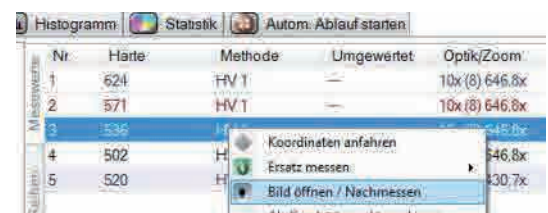

Measurement

Operator independent manual measurement

Due to the pixel-precise display of the indentation picture and the coloured measuring marks each in-

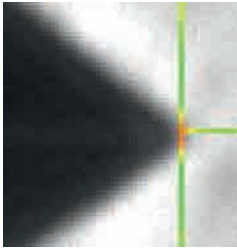

Red: too hard

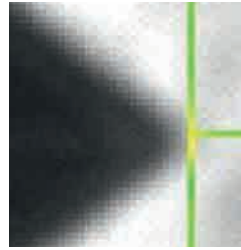

Yellow: ok

Automatic light control

High reproducibility and precision with the KB light control since the optimal illumination is achieved without operator influence. This is especially important at automatic test procedure when the sample surface or the magnifications are changing.

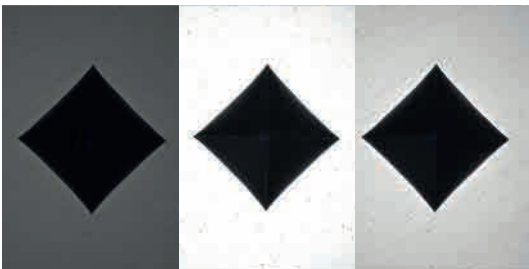

The **improved automatic evaluation** is now even more precise especially on not good surfaces.

Etched, sintered or scratched samples cannot inter-

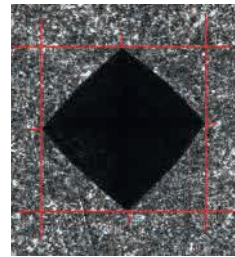

Etched surface

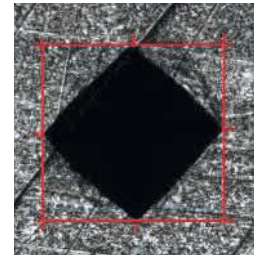

Scratched surface

Unique auto focus

The KB auto focus works reliably, quickly and precisely. The correct position does not need to be set by the operator at first.

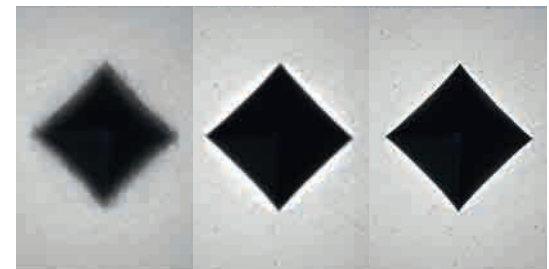

Scanning with KB Hardwin XL and the KB X/Y auto stage

Contour scan with the microscope camera:

Just the outline contour of the sample will be scanned with the microscope camera. The single pictures will be assembled.



Area scan with the microscope camera:

The complete sample will be scanned with the microscope camera. The size of the scan area can be freely chosen. The single pictures will be assembled.



Data management

Data export

The data export is supported by **html**, **pdf**, **Excel**, **Word** or **txt**.



Scanner

KB Hardwin XL supports bar code scanner as well as QR code scanner.

Thus, the sample data can be easily downloaded.



Test Report

Example for a possible test report

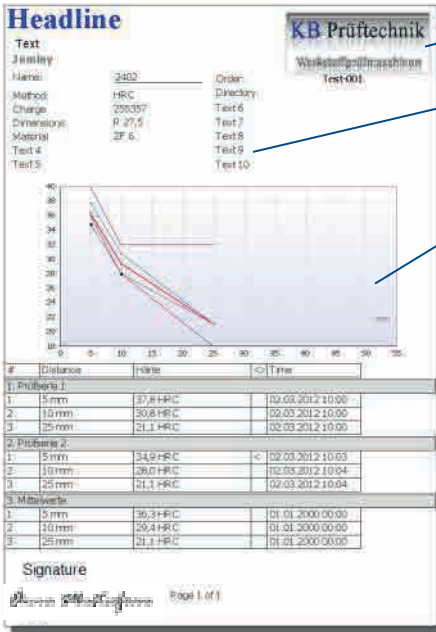

Customized logos can be embedded

Number and content of the property labels are freely

Diagrams and patterns can be integrated into the

The test reports can be freely adjusted by the report generator.

KB includes the generator in each software packet with standard report types. Special test report types can be programmed on request.

The test reports can also be programmed by the operator if required.

The file format of the report can be chosen between

Automated Data Management



Sample with bar or QR code on the lot slip



The code will be scanned and the saved order information and parameters will be downloaded of the ERP server.



The test order will be processed.



The measuring results will be exported and saved on the ERP server.



Part Recognition Reco Jet

After the scanning the right previously saved counter line with pattern will be recognized.
 Position and angle will be identified accurately
 The pattern will be applied automatically on the right sample coordinates
 Extensive time saving since the pattern of

Magazine

Customized magazine patterns can be programmed to test several samples of one kind.

Jominy - end quench test

The sample will be slightly grinded in longitudinal direction. Afterwards it will be positioned in the special sample holder and will be clamped. The hardness is measured alongside the test area. The hardenability follows of the hardness tests and the diagram which shows the hardening progress.

Sinter testing

CHD tests on sinter material
 Average-values curve is supported
 Automatic elimination of minimum and maximum values
 Interactive elimination of disadvantageously set indentations
 Indentation coordinates will be interactively checked and can be corrected
 Visualisation of the expected indentation size and

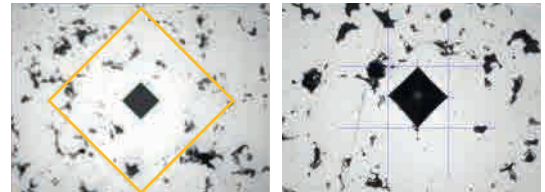

Quicklink

Adjust all test series of one pattern with one click.
 Orientation on significant points such as symmetry points, reference points, bench marks or pivotal

Pattern test

Fully automatic pattern test without any operator influence.

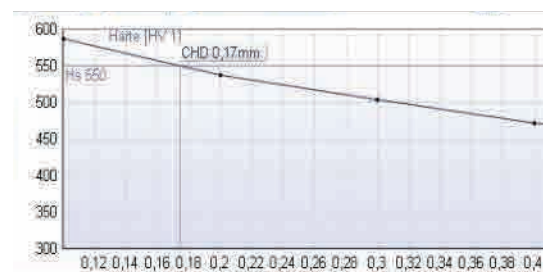
Time saving: The core hardness can be defined. If this value is reached, an adjustable number of indentations will be set before the test procedure will be completed.



Heat Exchanger

For surrounding temperatures over 30°C
 For dirty environment
 Mounted on the backside of the machine



Supports

Please contact our sales or service department concerning your special projects. We would like to help



Automatischer Revolver

6 Positionen für 4 Eindringkörper und 2 Objektive
 Automatischer Wechsel von Eindringkörpern und Objektiven
 Spannkappe optional



Manual X/Y stages

Manual X/Y stage for KB 250,
 25x25mm movement
 Manual X/Y stage for KB 250-750,
 50x50mm movement
 Manual X/Y stage for KB 3000,

Indenters

We do offer a huge variation of indenters. Please contact our sales or service department for any help.



Test Room Extension

Test room extension to 560 mm
 Test room extension to 700 mm
 Test room extension to 800 mm

Motor Driven Spindle

Comfortable lifting, even of heavy samples
 No manual hand drive
 Auto stop by clamping device

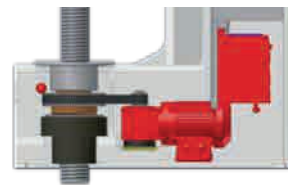

Auto X/Y stages

Auto X/Y stage for KB 150- 250,
 180x180 movement
 Auto X/Y stage for KB 250,
 300x200mm movement
 Auto X/Y stage for KB 250-1000,
 300x200mm movement
 Auto X/Y stage for KB 3000,
 300x200mm movement

Load Steps (controlled by one load cell)



Vickers acc. to DIN EN ISO 6507 and ASTM E 384

Load steps	0,2	0,3	0,5	1	2	3	5	10	20	30	40	50	60	80	100	120
KB 250																
KB 750																
KB 1000																
KB 3000																



Knoop acc. to DIN EN ISO 4545 and ASTM A 384

Load steps	0,2	0,3	0,4	0,5	0,6	0,7	0,8	0,9	1	2	3	5	10
KB 250													
KB 750													
KB 1000													
KB 3000													



Brinell acc. to DIN EN ISO 6506 and ASTM E 10

Load steps	1/1	1/1,25	1/2,5	1/5	1/10	1/30	2,5/6,25	2,5/15,625	2,5/31,25	2,5/62,5	2,5/187,5	5/25	5/62,5	5/125	5/250
KB 250															
KB 750															
KB 1000															
KB 3000															

Load steps	5/750	10/100	10/125	10/250	10/500	10/1000	10/1500	10/3000
KB 250								
KB 750								
KB 1000								
KB 3000								

	Standard
	Including option XL Load
	Not acc. to standards

Further load steps on request.



Rockwell (optional) acc. to DIN EN ISO 6508, ASTM D 785 and ASTM E 18
Super Rockwell



Ball indentation hardness acc. to DIN ISO 2039 T1 for plastics

HRA- HRB- HRC- HRD- HRE- HRF- HRG- HRH- HRK- HRL- HRM- HRP- HRR- HRS- HRV	HR 15/ 30/ 45 W
HR 15/ 30/ 45 N	HR 15/ 30/ 45 X
HR 15/ 30/ 45 T	HR 15/ 30/ 45 Y

Closed Loop Load Application

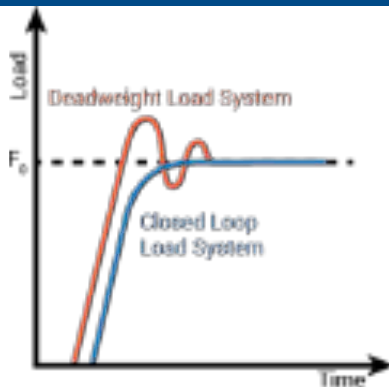

Systematically comparison deadweight

Due to the closed loop system the KB 250-3000 Video, SA, FA product range achieves a high precision test load range from 0,2 - 250 kgf without load variation.

Maximum precision:

The KB hardness testing machines apply the load controlled by a closed loop system. The **controlled load application** provides more accurate loads compared to a position controlled load application because the load will be supervised during the complete test procedure.

Load application time: Flexible and according to the standard

The application and the dwell time can be individually adjusted.

Advantages compared to the deadweight system:

In the closed loop system the test load which is applied on the indenter will be constantly measured and adjusted. The load overshoot behaviour is eliminated since the closed loop system con-

KB optical zoom



Optical magnification

The KB 250 MSHR is optionally equipped with the **KB optical zoom** (1:7 magnification in 10 steps). The optical zoom enlarges optically, not digitally. This allows a high picture quality, even in big magnifications.

Time and cost saving

The KB optical zoom reduces costs since it can **replace up to 4 objectives**.

Testing according to standards DIN EN ISO and ASTM

Systematical display of the measuring ranges of the different cameras

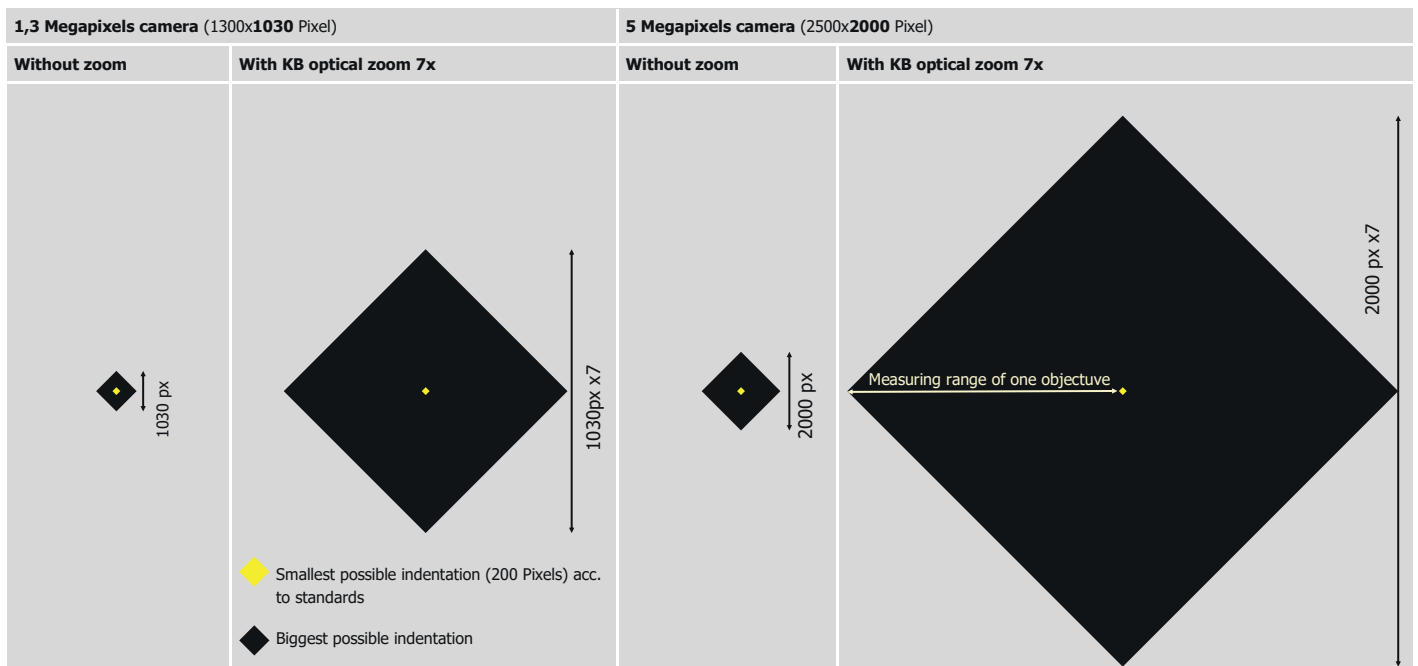

Overview optical measuring range with the 5 Megapixels camera

Hardness tester:	250		750		1000		3000	
	Min	Max	Min	Max	Min	Max	Min	Max
Optical measuring range with digital zoom								
4x objective Standard KB 750, 1000,	HV 20 (100µm)	HB 5/250 (3800µm)	HV 20 (100µm)	HB 5/250 (3800µm)	HV 30 (140µm)	HB 10/1000 (5300µm)	HV 30 (140µm)	HB 10/3000 (5300µm)
10x objective Standard KB 250	HV 2 (60µm)	HB 2,5/187,5 (1500µm)	HV 2 (60µm)	HB 2,5/187,5 (1500µm)	HV 3 (56µm)	HB 5/750 (2100µm)	HV 5 (56µm)	HB 5/750 (2100µm)
20x objective	HV 0,5 (20µm)	HV 50 (750µm)	HV 0,5 (20µm)	HV 50 (750µm)	-	-	-	-
Optical measuring range with optical zoom								
4x objective Standard KB 1000, 3000	HV 10 (120µm)	HB 5/250 (6000µm)	HV 10 (120µm)	HB 5/750 (6000µm)	HV 10 (120µm)	HB 10/1000 (6000µm)	HV 10 (120µm)	HB 10/3000 (6500µm)
10x objective Standard KB 250, 750	HV 1 (48µm)	HB 5/250 (2547µm)	HV 1 (48µm)	HB 5/250 (2547µm)	HV 1 (48µm)	HB 5/250 (2547µm)	HV 1 (48µm)	HB 5/250 (2547µm)
20x objective	HV 0,2 (24µm)	HB 2,5/187,5 (1273µm)	HV 0,2 (24µm)	HB 2,5/187,5 (1273µm)	HV 0,2 (24µm)	HB 2,5/187,5 (1273µm)	HV 0,2 (24µm)	HB 2,5/187,5 (1273µm)

Machine Dimensions - Indication in [mm]

	KB 250 KB 750 KB 1000 Standard	KB 250 KB 750 KB 1000 Art. Nr.: 1228	KB 250 KB 750 KB 1000 Art. Nr.: 1630	KB 250 KB 750 KB 1000 Art. Nr.: 1394	KB 3000 Standard	KB 3000 Art. Nr.: 1254
A	1180	1430	1638	1738	1290	1645
B	232	232	232	232	282	282
C Test room	320* (270)	560* (510)	700* (650)	800* (750)	350* (295)	700* (645)
D	250	250	250	250	250	250
E	736	736	735	735	797	797
G	320	320	320	320	334	334
H (flexible)	880-950	880-950	880-950	880-950	880-950	880-950
Weight	225 kg	240 kg	250 kg	255 kg	418 kg	443 kg

*Test room height C without spindle protection and X/Y stage, special dimensions on request.
 Test room height C including standard test table.
 () C including spindle protection.

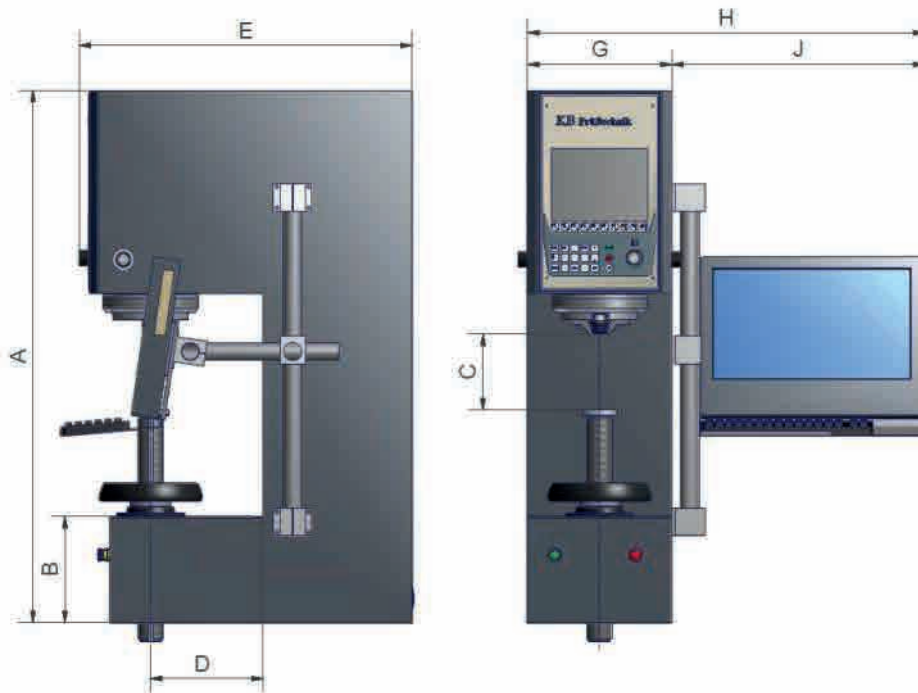
Technical Data

Hardness testing machine:	KB 250	KB 750	KB 1000	KB 3000
Max. sample weight	100 kg	100 kg	100 kg	250 kg
Max. sample weight incl. X/Y stage	25 kg	50 kg	25 kg	25 kg
Throat depth	250 mm	250 mm	250 mm	250 mm
Durability of the LED light	> 10 years	> 10 years	> 10 years	> 10 years
Magnification optical zoom	1:7 in 10 steps	1:7 in 10 steps	1:7 in 10 steps	1:7 in 10 steps
Weight without auto X/Y stage	ca. 235 kg	ca. 245 kg	ca. 250 kg	ca. 440 kg
Weight with auto X/Y stage	ca. 244 kg	ca. 268 kg	ca. 305 kg	ca. 495 kg
Supply voltage	230 VAC, 3 A	230 VAC, 3 A	230 VAC, 3 A	230 VAC, 3 A

Ausstattungsvarianten und Optionen

Legend	
Symbol	Meaning
-	Not applicable
X	Including
O	Option

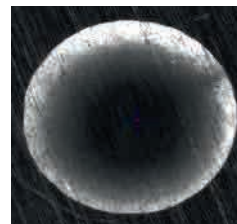

	Video		SA		FA Basic		FA	
	KB 250-750	KB 1000-3000	KB 250-750	KB 1000-3000	KB 250-750	KB 1000-3000	KB 250-750	KB 1000-3000

Hardware

5 Megapixels USB	X	X	X	X	X	X	X	X
Test table	Diameter 80 mm	Diameter 148 mm	Auto X/Y stage 180x180 mm movement	Auto X/Y stage 300x200 mm movement	Auto X/Y stage 180x180 mm movement	Auto X/Y stage 300x200 mm movement	Auto X/Y stage 180x180 mm movement	Auto X/Y stage 300x200 mm movement
Load range [kgf]	0,5 - 250 1 - 750	3 - 1000 5 - 3000	0,5 - 250 1 - 750	3 - 1000 5 - 3000	0,5 - 250 1 - 750	3 - 1000 5 - 3000	0,5 - 250 1 - 750	3 - 1000 5 - 3000
Optional load range	0,2 - 187,5 0,3 - 250	-	0,2 - 187,5 0,3 - 250	-	0,2 - 187,5 0,3 - 250	-	0,2 - 187,5 0,3 - 250	-
Load step	O	-	O	-	O	-	O	-
Option Rockwell	O	O	O	O	O	O	O	O

Software

Auto measurement for Vickers and Knoop incl. light control and	O	O	O	O	X	X	X	X
Auto measurement for Brinell incl. light control	O	X	O	X	X	X	X	X
Multi Sampling	-	-	O	O	O	O	X	X
Part recognition	-	-	O + Scanning	O + Scanning	O + Scanning	O + Scanning	X	X
Scanning	-	-	O + Auto focus	O + Auto focus	O	O	X	X
Auto focus	O	O	O	O	X	X	X	X
Manual CHD Test	O	O	-	-	-	-	-	-
Graphical Editor	-	-	X	X	X	X	X	X
Quick Link	-	-	O + Scanning	O + Scanning	O + Scanning	O + Scanning	X	X
Light Control	O	O	O	O	X	X	X	X
Welding Option	-	-	O + Scanning	O + Scanning	O + Scanning	O + Scanning	X	X
Geometrical Tools	-	-	O + Scanning	O + Scanning	O + Scanning	O + Scanning	X	X
Sinter	-	-	-	-	O	O	O	O
AMS interface	O	O	O	O	O	O	O	O



Your Representative
CONTROL Y MEDICIÓN
LABORATORIO DE CALIBRACIÓN
COMERCIALIZADORA

Bussines Park Sendero Advance
Prolongación Boulevard Bernardo Quintana #2481,
Nave 27, Col. Felipe Carrillo Puerto, Querétaro, Qro.
C.P. 76138

www.controlymedicion.com.mx
info@controlymedicion.com
Teléfonos: (442) 340-0250, 340-0251, 442 193 5678



KB 250-3000 Video, SA, FA-eng-04-2017

KB Prüftechnik GmbH
Im Weichlingsgarten 10 b
67126 Hochdorf – Assenheim

Tel: +49-6231 – 93992-0
Fax: +49-6231 – 93992-69

Email: info@kbprueftechnik.de
Internet: www.kbprueftechnik.com

Information under reserve.